

# *GR 47/GR 48*

## *Technical Description*

# CE

The product described in this manual conforms to the Radio Equipment and Telecommunication Terminal Equipment (R&TTE) directive 99/5/EC with requirements covering EMC directive 89/336/EEC and Low Voltage directive 73/23/EEC. The product fulfils the requirements according to 3GPP TS 51.010-1, EN 301489-7 and EN60950.

The information contained in this document is the proprietary information of **Sony Ericsson Mobile Communications**. The contents are confidential and any disclosure to persons other than the officers, employees, agents or subcontractors of the owner or licensee of this document, without the prior written consent of **Sony Ericsson Mobile Communications**, is strictly prohibited.

Further, no portion of this publication may be reproduced, stored in a retrieval system, or transmitted in any form or by any means, electronic or mechanical, including photocopying and recording, without the prior written consent of **Sony Ericsson Mobile Communications**, the copyright holder.

## **Second edition (February 2003)**

**Sony Ericsson Mobile Communications**. publishes this manual without making any warranty as to the content contained herein. Further **Sony Ericsson Mobile Communications**. reserves the right to make modifications, additions and deletions to this manual due to typographical errors, inaccurate information, or improvements to programs and/or equipment at any time and without notice. Such changes will, nevertheless be incorporated into new editions of this manual.

All rights reserved.

© **Sony Ericsson Mobile Communications.**, 2003

Publication number:

Printed in UK

## Contents

<b>1</b>	<b>INTRODUCTION .....</b>	<b>5</b>
1.1	OVERVIEW .....	5
1.2	FEATURES .....	6
1.2.1	<i>Type of Mobile Station</i> .....	6
1.2.2	<i>SMS</i> .....	7
1.2.3	<i>Voice calls</i> .....	7
1.2.4	<i>Data</i> .....	7
1.2.5	<i>SIM Card</i> .....	8
1.2.6	<i>Power consumption</i> .....	8
1.2.7	<i>Other features</i> .....	8
1.2.8	<i>Development Kit</i> .....	8
1.3	PRECAUTIONS .....	9
1.4	ABBREVIATIONS .....	9
<b>2</b>	<b>MECHANICAL DESCRIPTION .....</b>	<b>11</b>
2.1	INTERFACE DESCRIPTION .....	11
2.2	PHYSICAL DIMENSIONS .....	12
<b>3</b>	<b>SYSTEM CONNECTOR INTERFACE .....</b>	<b>13</b>
3.1	OVERVIEW .....	13
3.2	GENERAL ELECTRICAL AND LOGICAL CHARACTERISTICS.....	16
3.2.1	<i>General Protection Requirements</i> .....	17
3.3	GROUNDING .....	18
3.3.1	<i>The Analogue Ground</i> .....	18
3.3.2	<i>The Digital Ground (DGND)</i> .....	18
3.4	REGULATED POWER SUPPLY .....	19
3.4.1	<i>Power Supply (VCC)</i> .....	19
3.4.2	<i>Battery Charging Input (CHG_IN)</i> .....	19
3.5	ON/OFF AND EXTERNAL POWER SIGNALS.....	20
3.5.1	<i>Module ON/OFF</i> .....	20
3.5.2	<i>External 2.75 V (VIO)</i> .....	21
3.6	ANALOGUE AUDIO .....	22
3.6.1	<i>Audio To Mobile Station (ATMS)</i> .....	22
3.6.2	<i>Audio From Mobile Station (AFMS)</i> .....	24
3.7	MICROPHONE SIGNALS .....	24
3.8	SPEAKER SIGNALS .....	25
3.9	DIGITAL AUDIO.....	25
3.10	SERIAL DATA .....	27
3.10.1	<i>UART 1 (RS232) - RD, TD, RTS, CTS, DTR, DCD, DSR and RI</i> .....	29
3.10.2	<i>Serial Data Signals - RD, TD</i> .....	29
3.10.3	<i>Control Signals - RTS, CTS, DTR, DCD, RI, DSR</i> .....	30
3.10.4	<i>UART 2 - TD2, RD2</i> .....	32
3.10.5	<i>UART 3 - TD3, RD3</i> .....	32
3.11	SIM CARD RELATED SIGNALS.....	33
3.11.1	<i>SIM Detection – SIM Presence</i> .....	34
3.12	SERVICE/PROGRAMMING .....	34
3.13	BUZZER.....	35
3.14	LED .....	35
3.15	TX_ON - BURST TRANSMISSION.....	36
3.16	REAL TIME CLOCK .....	36
3.17	EXTENDED IO CAPABILITIES.....	37
3.17.1	<i>LED/IO6</i> .....	37
3.17.2	<i>I#/O#</i> .....	37

3.17.3	UART3/IO# .....	37
3.17.4	IO# / ADC# .....	37
3.18	KEYBOARD INTERFACE .....	39
3.18.1	IO# / KEYROW#.....	39
3.18.2	KEYCOL#.....	39
<b>4</b>	<b>ANTENNA CONNECTOR.....</b>	<b>41</b>
<b>5</b>	<b>AT COMMAND SUMMARY .....</b>	<b>42</b>
<b>6</b>	<b>EMBEDDED APPLICATIONS .....</b>	<b>45</b>
6.1	FEATURES .....	45
6.2	IMPLEMENTATION.....	45
6.2.1	<i>Limitations</i> .....	45
6.2.2	<i>IDE (Integrated Developers Environment)</i> .....	46
<b>7</b>	<b>TCP/IP STACK .....</b>	<b>47</b>
7.1	IMPLEMENTATION.....	47
<b>8</b>	<b>TECHNICAL DATA .....</b>	<b>48</b>
<b>9</b>	<b>CONTACT DETAILS .....</b>	<b>50</b>

## 1 Introduction

### 1.1 Overview

The GR47/GR48 belong to a new generation of Sony Ericsson Mobile Communications GSM modules. This document describes the main characteristics and functionality of the GR47/48, two dual band products for 900/1800 MHz and 850/1900 MHz GSM bands respectively.

They are intended to be used in both machine-to-machine applications and man-to-machine applications. The module serves its purpose when there is a need for sending and receiving data (by SMS, CSD, HSCSD, or GPRS), as well as making voice calls over the GSM network.

GR47/GR48 are business-to-business products. It is intended to be sold to manufacturers, system integrators, applications developers-developing solutions with wireless communication. The module is intended to be integrated by the system integrator within an application. The module and the external application will form a system for wireless communication.

A typical system is one where a micro controller in an external application communicates with the module over its serial interface. The micro controller will control the module, via the supported set of AT commands. It is assumed that the system integrators have a high technical knowledge and the ability to integrate the module into a system. For the GR47/GR48 modules some interesting applications are the following:

- Fleet and Asset Management
- Vending Machines
- Security and Alarm
- Other telemetry applications

## 1.2 Features

The module performs a set of telecom services (TS) according to GSM standard phase 2+, ETSI and ITU-T. The functions of the module are implemented by issuing AT commands over the serial interface. Supported AT commands are listed in section 5, these are defined further in GSM 7.05/7.07 and the GR47/GR48 integrator's manual.

### 1.2.1 Type of Mobile Station

The GR4X family are normal dual band type of MS with the following characteristics.

GR47	GSM 900	E-GSM 900	GSM 1800
Frequency Range (MHz)	TX: 880-915 RX: 935-960	TX: 880-890 RX: 925-935	TX: 1710-1785 RX: 1805-1880
Channel spacing	200 kHz		200 kHz
Number of channels	173 Carriers *8 (TDMA) GSM: Channels 1 to 124 E-GSM: Channels 975 to 1023		374 Carriers *8 (TDMA) DCS: Channels 512 to 885
Modulation	GMSK		GMSK
TX Phase Accuracy	< 5° RMS Phase error (burst)		< 5° RMS Phase error (burst)
Duplex spacing	45 MHz		95 MHz
Receiver sensitivity at antenna connector	< - 102 dBm		< - 102 dBm
Transmitter output power at antenna connector	Class 4 2W (33 dBm)		Class 1 1W (30 dBm)
Automatic hand-over between GSM 900 and GSM 1800			
GR48	GSM 850	GSM 1900	
Frequency Range (MHz)	TX: 824-849 RX: 869-894	TX: 1850-1910 RX: 1930-1990	
Channel spacing	200 kHz		200 kHz
Number of channels	123 carriers *8 (TDMA) GSM: Channels 128 to 251		298 Carriers *8 (TDMA) PCS: Channels 512 to 810
Modulation	GMSK		GMSK
TX Phase Accuracy	< 5° RMS Phase error (burst)		< 5° RMS Phase error (burst)
Duplex spacing	45 MHz		80 MHz
Receiver sensitivity at antenna connector	< - 102 dBm		< - 102 dBm
Transmitter output power at antenna connector	Class 5 0.8 W (29 dBm)		Class 1 1W (30 dBm)
Automatic hand-over between GSM 850 and GSM 1900			

## 1.2.2 SMS

The module supports the following SMS services:

- Sending: MO, both PDU and Text mode supported.
- Receiving: MT, both PDU and Text mode supported.
- CBM is a service, in which a message is sent to all subscribers located in one or more specific cell(s) in the GSM network, for example, cell location information.
- SMS STATUS REPORT according to GSM 03.40.

The maximum length of an SMS message is 160 characters when using 7-bit encoding. For 8-bit data, the maximum length is 140 characters.

The module supports upto 6 concatenated messages to extend this function.

## 1.2.3 Voice calls

The GR47/GR48 offers the capability of MO and MT voice calls, as well as supporting emergency calls. In addition to this multiparty, call waiting and call deflection features are available. Some of these features are operator specific.

The module offers normal analogue input/output lines, analogue audio input/ output lines in differential modes, and digital audio interface, with the possibility of accessing internal points within the digital audio lines. Moreover, the GR47/GR48 have an embedded echo canceller and noise suppression, which provide high quality audio.

The module supports HR, FR and EFR voice coding, provided that EFR is available in the network.

## 1.2.4 Data

The module supports the following data protocols:

- *General Packet Radio Service (GPRS)*. The modules are Class B Terminals, which provides simultaneous activation and attach of GPRS and GSM services. The GR47/GR48 modules are GPRS 4+1 devices, which are capable of transmitting in one timeslot per frame (uplink), and receiving in a maximum of four timeslots per frame (downlink).
- *Circuit Switched Data (CSD)*. GR47/GR48 modules are capable of establishing a circuit switch data link at 9.6 kbps.
- *High Speed Circuit Switched Data (HSCSD)*. GR47/GR48 supports HSCSD communication, with one timeslot per frame capacity in the uplink and two timeslots per frame capacity in the downlink (2+1).

### 1.2.5 SIM Card

The module supports the connection of an external SIM Card with 3V or 5 V technology, via the 60-pin system connector. The module does not have an internal SIM holder.

### 1.2.6 Power consumption

	Stand-by	Transmit/Operation
GSM 850 & 900 MHz	<5 mA	275 mA (2A peak)
GSM 1800 & 1900 MHz	<5 mA	250 mA (1.75A peak)

*Note!* The power consumption during transmission is measured at maximum transmit power.

### 1.2.7 Other features

- 07.10 Multiplexing
- GPS interoperability
- SIM application toolkit, class 2 release 96 compliant
- Embedded application (see section 6)
- On board TCP/IP stack (see section 7)

### 1.2.8 Development Kit

Sony Ericsson Mobile Communications provides the opportunity to test the module in a limited scale, before ordering a large quantity.

#### 1.2.8.1 M2mpower Package

With the M2mpower package you can quickly get started with the module. The developer's Kit as part of the M2mpower Package includes necessary accessories (software and hardware) that you will need for your test purposes. It also includes the following:

- GSM module GR47 or GR48
- Integrator's Manual
- M2mpower IDE
- M2mpower application guide

The Integrator's Manual provides you with all the information you need to be able to integrate the module with your application. The Embedded Applications software IDE is supplied ready to run on a



suitable PC and comes with extensive help files, training course and support.

### 1.2.8.2 Developer's kit

As an alternative, the Integrator's Manual and Universal Development Board are available as a separate offering. The kit includes other necessary accessories (software and hardware) that you will need for your test purposes

These are available from your regional salesperson or M2M customer support (see section 7)

## 1.3 Precautions

The GR47/GR48 should be handled like any mobile station. In the Integrators' Manual you will find more information about safety and product care. In the Technical Data chapter in this document the environmental and electrical limits are specified. Never exceed these limits to ensure the module is not damaged.

## 1.4 Abbreviations

<i>Abbreviation</i>	<i>Explanation</i>
ATMS	Audio To Mobile Station
AFMS	Audio From Mobile Station
CBS	Cell Broadcast Service
CBM	Cell Broadcast Messaging
CSD	Circuit Switch Data
DCE	Data Circuit Terminating Equipment
DTE	Data Terminal Equipment
DTMF	Dual Tone Multi Frequency
EA	Embedded Applications
EFR	Enhanced Full Rate codec
EMC	Electro-Magnetic Compatibility
ETSI	European Telecommunications Standards Institute
FR	Full Rate codec
GPRS	General Packet Radio Service
GPS	Global Positioning System
GSM	Global System for Mobile Communication
HR	Half Rate codec
HSCSD	High Speed Circuit Switched Data
IDE	Integrated Developers Environment

---

IP	Internet Protocol
ITU-T	International Telecommunication Union – Telecommunications Standardisation Sector
ME	Mobile Equipment
MMCX	Micro Minature Coax
MO	Mobile Originated
MS	Mobile Station
MT	Mobile Terminated
PCM	Pulse Code Modulation
PDU	Protocol Data Unit
RLP	Radio Link Protocol
RF	Radio Frequency
RFU	Reserved for Future Use
RTC	Real Time Clock
SDP	Service Discovery Protocol
SMS	Short Message Service
SIM	Subscriber Identity Module
TCP	Transport Control Protocol
TBD	To Be Defined
UDP	User Datagram Protocol

---

## 2 Mechanical Description

### 2.1 Interface Description

The picture below presents the conceptual mechanical design of the GR47/48. The GR47/GR48 are protected with AISI 304 Stainless Steel covers suitable to fulfil the environmental and EMC requirements. Dimensions, the position of the different connectors and mounting holes are shown in figure 2.2.

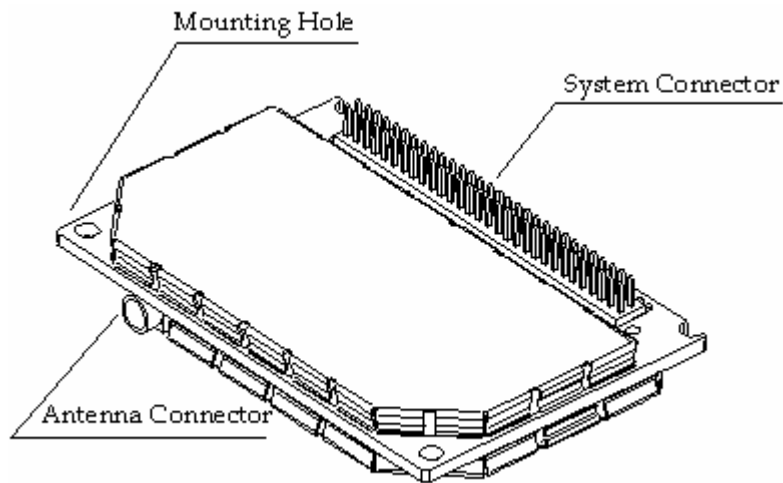

Figure 2.1 GR 47/48, view from the underside

## 2.2 Physical Dimensions

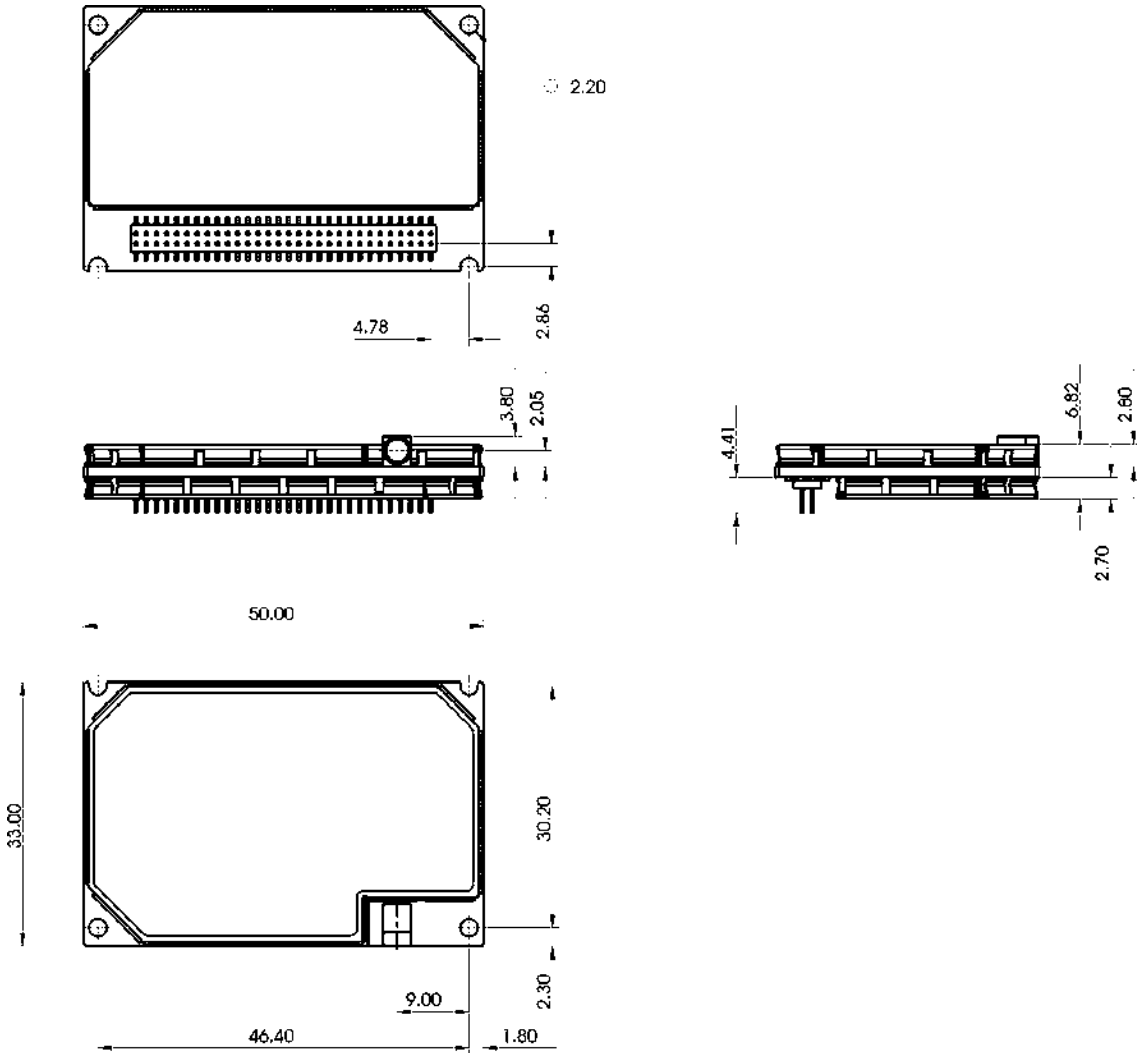

Figure 2.2 Physical dimensions of GR 47/48

The measures are given in millimetres. See also chapter 6, Technical Data.

## 3 System Connector Interface

### 3.1 Overview

The electrical connections to the module (except the antenna), are made through the System Connector Interface.

The connector shall allow the following connections: board to board and board to cable. Details of connector availability and sources are available from customer support on request.

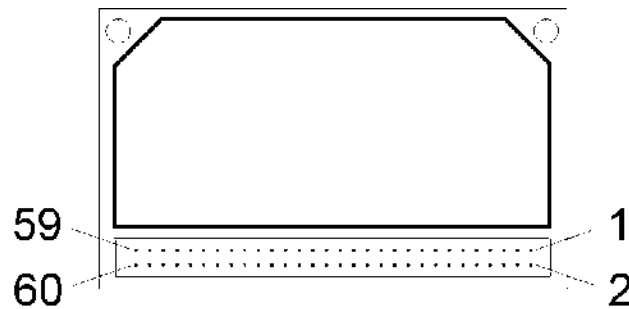

*Figure 3.1 GR 47/48. View from the underside*

The table on next page provides the pin assignment of the different signals in the System Connector Interface as well as a short description of them.

All signal directions are with respect to the module i.e. Direction 'O' means data being sent by the module.

Pin	Signal Name	Dir	Signal Type	Description
1.	VCC	-	Supply	Power Supply
2.	DGND	-	-	Digital Ground
3.	VCC	-	Supply	Power Supply
4.	DGND	-	-	Digital Ground
5.	VCC	-	Supply	Power Supply
6.	DGND	-	-	Digital Ground
7.	VCC	-	Supply	Power Supply
8.	DGND	-	-	Digital Ground
9.	VCC	-	Supply	Power Supply
10.	DGND	-	-	Digital Ground
11.	CHG_IN	-	Batt Charge (power)	Battery charging
12.	DGND	-	-	Digital Ground
13.	IO5	I/O	Dig 2.75	General Purpose input/output 5
	ADC4	I	Analogue	Analogue to digital converter 4
14.	ON/OFF	I	Internal pull up, open drain	Turns the module on/off Former WAKE_B
15.	SIMVCC	-	Dig. 3/5 V	SIM card power supply Power output for SIM Card from module
16.	SIMPRESENCE	I	Internal pull up, open drain	SIM Presence A "1" shall indicate that the SIM is missing; a "0" that it is inserted.
17.	SIMRST	O	Dig. 3/5 V	SIM card reset
18.	SIMDATA	I/O	Dig. 3/5 V	SIM card data
19.	SIMCLK	O	Dig. 3/5 V	SIM card clock
20.	DAC	O	Analogue	Digital to Analogue converter
21.	IO1	I/O	Digital, 2.75	General purpose input/output 1
	KEYROW2	I		Keyboard row 2
22.	IO2	I/O	Digital, 2.75	General purpose input/output 2
	ADC 5	I	Analogue	Analogue to digital converter 5
23.	IO3	I/O	Digital, 2.75	General purpose input/output 3
	KEYROW3	I		Keyboard row 3
24.	IO4	I/O	Digital, 2.75	General purpose input/output 4
	KEYROW4	I		Keyboard row 4
25.	VRTC	I	Supply 1.8 V	Voltage for real time clock
26.	ADC1	I	Analogue	Analogue to digital converter 1
27.	ADC2	I	Analogue	Analogue to digital converter 2

28.	ADC3	I	Analogue	Analogue to digital converter 3
29.	SDA	I/O	2.75, internal pullup	I <sup>2</sup> C Data
30.	SCL	O	2.75, internal pullup	I <sup>2</sup> C Clock
31.	BUZZER	O	Dig. 2.75	Buzzer output from module
32.	O3	O	Dig. 2.75	General purpose output 5
	KEYCOL3	O		Keyboard column 3
	DSR	O		Data Set Ready
33.	LED	O	Dig. 2.75	Flashing LED
	IO6	I/O		General purpose I/O 6
34.	VIO	O	Power Out 2.75	Module powered indication. The VIO is a 2.75 V output that could power external devices to transmit data towards the GSM device to a 75mA max.
35.	TX_ON	O	Dig 2.75	This output shall indicate when the GSM module is going to transmit the burst.
36.	RI	O	Dig. 2.75	Ring Indicator
	KEYCOL2	O		Keyboard column 2
	O2	O		General purpose output 2
37.	DTR	I	Dig. 2.75	Data Terminal Ready
	KEYROW1	I		Keyboard row 1
	IN1	I		General purpose input 1
38.	DCD	O	Dig. 2.75	Data Carrier Detect
	KEYCOL1	O		Keyboard column 1
	O1	O		General purpose output 1
39.	RTS	I	Dig. 2.75	Request To Send
	IO9	I/O		General purpose I/O 9
40.	CTS	O	Dig. 2.75	Clear To Send
	KEYCOL4	O		Keyboard column 4
	O4	O		General purpose output 4
41.	TD	I	Dig. 2.75	Transmitted Data [former DTMS]
42.	RD	O	Dig. 2.75	Received Data [former DFMS]
43.	TD3	I	Dig. 2.75	UART3 Transmission
	I/O7	I/O		General purpose I/O 7
44.	RD3	O	Dig. 2.75	UART3 Reception
	I/O8	I/O		General purpose I/O 8
45.	TD2	I	Dig. 2.75	UART2 Reception [Former CTMS]
46.	RD2	O	Dig. 2.75	UART2 Transmission [Former CFMS]

47.	PCMULD	I	Dig. 2.75	DSP PCM digital audio input
48.	PCMDLD	O	Dig. 2.75	DSP PCM digital audio output
49.	PCMO	O	Dig. 2.75	Codec PCM digital audio output
50.	PCMI	I	Dig. 2.75	Codec PCM digital audio input
51.	PCMSYNC	O	Dig. 2.75	DSP PCM frame sync
52.	PCMCLK	O	Dig. 2.75	DSP PCM clock output
53.	MICP	I	Analogue	Microphone input positive
54.	MICN	I	Analogue	Microphone input negative
55.	BEARP	O	Analogue	Speaker output positive
56.	BEARN	O	Analogue	Speaker output negative
57.	AFMS	O	Analogue	Audio output from module
58.	SERVICE	I	12V/2.7V	Flash programming voltage for the MS. Enable logger information if no flashing Former VPPFLASH
59.	ATMS	I	Analogue	Audio input to module
60.	AGND	-	Analogue	Analogue ground

Note : Although the pin out has changed the unit remains backwardly compatible with the GM47.

### 3.2 General Electrical and Logical Characteristics

Many of the signals present in the interface are high-speed CMOS logic inputs or outputs powered from  $2.75\text{ V} \pm 5\%$ . Whenever a signal is defined as Dig. 2.75 V, the following electrical characteristics shall apply.

Parameter	Min.	Typ.	Max.	Units	Output Current $I_o$
High Level Output Voltage ( $V_{OH}$ )	2.2		2.75	Volts	- 2 mA
Low Level Output Voltage ( $V_{OL}$ )	0		0.6	Volts	2 mA
High Level Input Voltage ( $V_{IH}$ )	1.93		2.75	Volts	
Low Level Input voltage ( $V_{IL}$ )	0		0.5	Volts	



### 3.2.1 General Protection Requirements

All 2.75V digital inputs shall continuously withstand any voltage from -0.5V up to 3.47V (3.3V + 5%) in the power-on or power-off condition with no damage. All 2.75V digital outputs shall continuously withstand a short circuit to any voltage within the range from 0V to 3V.

*! Note :* This is for protection ONLY, the module cannot be driven directly by a 3.3V micro processor, if this is done it will invalidate any warranty claim on the module.

The SIM output signals and the SIMVCC supply can continuously withstand a short circuit to any voltage within the range from 0V to 4.1V.

### 3.3 Grounds

Pins	Name	Description
2, 4, 6, 8, 10, 12	DGND	Digital Ground
60	AGND	Analogue Ground

There are two ground signals in GR 47/48, Analogue Ground (AGND) and Digital Ground (DGND). The analogue Ground is connected to pin number 60, and the Digital Ground is connected to the System Connector Interface through pin numbers 2, 4, 6, 8, 10 and 12.

*Note:* All the Ground pins have to be connected to the application. The AGND is connected to the DGND in the ME, and *only* there. It is important that the AGND and the DGND are separated in the application.

#### 3.3.1 The Analogue Ground

The AGND lead is the analogue audio reference ground. It is the return signal for Audio To Mobile Station (ATMS) and Audio From Mobile Station (AFMS).

It shall be connected to the Digital Ground (DGND) inside the module and only there. The application shall not connect DGND and AGND.

Parameter	Limit
$I_{\max}$	$\cong 12.5\text{mA}$

#### 3.3.2 The Digital Ground (DGND)

DGND is the reference for all digital signals in the System Interface. It shall also be the DC return for the power supply on VCC and SERVICE. Each DGND pin is rated at 0.5 A. All DGND pins are connected internally in the module.

All DGND pins should be connected commonly in the application.

Parameter	Limit
$I_{\text{average}}$	< 0.5 A No DGND pin can withstand over 0.5 A
$I_{\max}$	< 600 mA (100 mA each)

### 3.4 Regulated Power Supply

<i>Pins</i>	<i>Name</i>	<i>Description</i>
1, 3, 5, 7, 9	VCC	Regulated Power Supply

The regulated power supply, VCC, is connected to the pin numbers 1, 3, 5, 7 and 9.

#### 3.4.1 Power Supply (VCC)

The VCC supplies the module with external power. Any other voltage needed is generated internally.

<i>Parameter</i>	<i>Mode</i>	<i>Limit</i>
Voltage to be applied	Nominal	3.6 Volts
	Tolerance including ripple <sup>1</sup>	3.4 Volts - 4.0 Volts
	Over voltages	5.5 Volts
Current Drive capability at TX Full Power		< 600 mA (average)
		< 2 A (Peak)

GR 47/48 have not internal capacitance to supply the large current peaks during GSM transmission. Therefore on burst transmission the application DC source is responsible for providing the appropriate current.

Design application notes are available from customer support on request.

#### 3.4.2 Battery Charging Input (CHG\_IN)

The battery charging pin is design to provide a charging current into a battery. The precise algorithm is TBD but it will be one of the following

- Generic charging algorithm implemented and further refinements for the algorithm to be implemented through embedded applications (see section 6)
- Specific charging algorithms for SEM approved batteries.

<sup>1</sup> Measured at system connector pins.

### 3.5 ON/OFF and External Power Signals

Pins	Name	Dir	Description
14	ON/OFF	I	Square signal to turn on/off the module
34	VIO	O	External power supply

#### 3.5.1 Module ON/OFF

The module is powered ON/OFF by grounding (pulling low) pin 14 as per figure 3.2 below. The pin should then be released as it has an internal pull up to return it to the high state.

*Note:* Driving with 2.75V or 3.6V is not permitted and restricts module functionality.

Parameter	Minimum	Typical	Maximum	Units
Voltage HIGH Level (FALSE)			VCC	By internal pull up only
Voltage LOW Level (TRUE)	0		0.3*VCC	Volts
Pull-up Resistance	Internal pull up		39	K $\Omega$

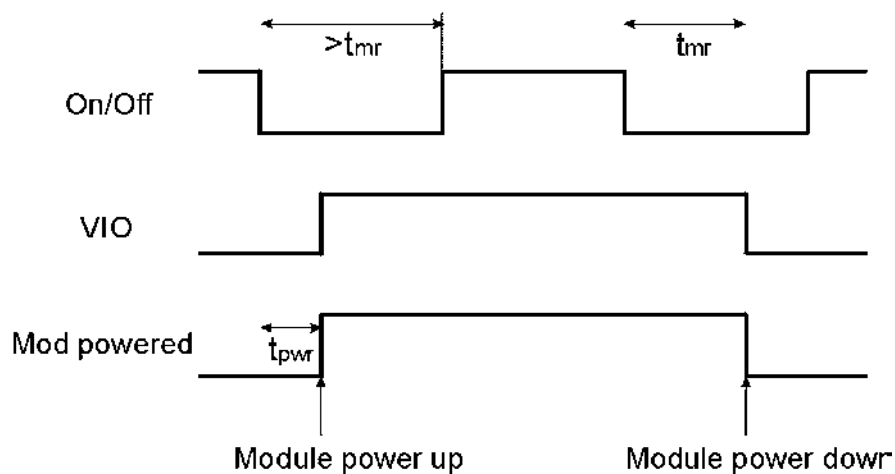

Figure 3.2 ON/OFF and VIO performance

Where the times are defined as follows:

Time	Description	Min	Typ	Max	Unit
$t_{mr}$	Time to start an ON/OFF operation	1	1.5		S
$t_{pwr}$	Time for module start-up once ON/OFF signal has set to TRUE	100		200	mS

### 3.5.2 External 2.75 V (VIO)

The VIO has been derived from a 2.75 V regulator. It is possible to use this output as a power supply at 2.75 V with a maximum of 75mA.

It will indicate that the module is alive and it could power external devices. In this case, the external applications do not need to implement a 2.75 volt regulator to adapt the incoming (from module point of view) serial data.

<i>Parameter</i>	<i>Minimum Typical Maximum</i>			<i>Units</i>
Output Voltage ( $I_{load}=50$ mA)	2.70	2.75	2.85	Volts
Load current			75	mA

### 3.6 Analogue Audio

<i>Pins</i>	<i>Name</i>	<i>Dir</i>	<i>Description</i>
57	AFMS	O	Audio From Mobile Station
59	ATMS	I	Audio To Mobile Station
60	AGND	-	Reference for analogue audio

ATMS and AFMS are the audio input and output for the module. The analogue audio signals can be used in two different modes, Handsfree and Portable Handsfree.

#### *Handsfree*

This mode is referred to as Audio To Mobile Station (ATMS) and Audio From Mobile Station (AFMS). It is used by audio accessories such as Handsets and Handsfree equipment.

#### *Portable Handsfree*

This mode activates a different amplification factor in the Mobile Equipment (ME). It also activates a microphone bias level in ATMS. This is the default mode.

#### 3.6.1 Audio To Mobile Station (ATMS)

ATMS is the analogue audio input to the module. It connects to the audio input of the CODEC in the module. The CODEC then converts the analogue audio to digital audio, in PCM format, which is connected to the internal PCM bus in the module. The internal PCM bus connects the encoded audio to PCMO on the system connector.

ATMS is also used as the microphone input from the Portable Handsfree. If this is the case, a DC bias is provided from the ATMS.

All sources must be AC-coupled except the Portable Handsfree microphone, which shall be DC-coupled in order to supply DC current to the Portable Handsfree microphone. AC coupling prevents incorrect biasing or damage of the ATMS input. The capacitor must have a value greater than shown below to avoid attenuation of low frequencies.

The ATMS input is a passive network followed by the transmit part of the CODEC.

<i>Parameter</i>	<i>Limit</i>
Application driving impedance (0.3 - 3.5 kHz)	< 300 $\Omega$
AC coupling capacitance <sup>2</sup>	> 1 $\mu$ F
Module input impedance (0.3 - 3.5 kHz)	>50K $\Omega$
Low frequency cut-off (- 3 dB)	300 Hz $\pm$ 50 Hz
High frequency cut-off (- 3 dB)	> 3500 Hz
Maximum allowed input level	1.5V <sub>pp</sub> = 530mV
Output DC bias level	Handsfree mode
	Portable Handsfree mode
	2 V
	2 V $\pm$ 0.1 V
Additional Gain in Portable Handsfree mode	28.5 dB

- Maximum input level at ATMS 245mV<sub>rms</sub> output at PCMO = 3dBm0.
- The following table is with nominal PGA (Programmable Gain Settings).
- For more information see AT commands in the integrators manual.

<i>Input</i>	<i>Input Volts mV<sub>rms</sub></i>	<i>TXAGC dB</i>	<i>AUX11 Gain</i>	<i>PCMO dBm0</i>
ATMS	245	0	13	3

Maximum input level at MICI 61.4mV<sub>rms</sub> output at PCMO = 3dBm0

<i>Input</i>	<i>Input Volts mV<sub>rms</sub></i>	<i>TXAGC dB</i>	<i>AUX11 Gain</i>	<i>PCMO dBm0</i>
MICI	61.4	0	25	3

Output at AUX02 for 3dBm0 at PCMI

<i>Input</i>	<i>dBm0</i>	<i>RXPGA</i>	<i>Volume Control dB</i>	<i>AUX02 mV<sub>rms</sub></i>
PCMI	3dBm0	0	0	436

Output at BEAR for 3dBm0 at PCMI

<i>Input</i>	<i>dBm0</i>	<i>RXPGA</i>	<i>Volume Control dB</i>	<i>BEAR mV<sub>rms</sub></i>
PCMI	3dBm0	0	0	388

<sup>2</sup> AC coupling capacitance must be supplied by the application, unless a DC coupled microphone is used.

### 3.6.2 Audio From Mobile Station (AFMS)

AFMS is the analogue audio output from the module. When it is active, the output is derived from the PCM digital audio by the decoder part of the CODEC. The PCM data comes from PCMI on the system connector. It is also used as an ear-piece driver for the Portable Hands Free accessory.

<i>Parameter</i>	<i>Limit</i>	
Speaker impedance	64 $\Omega$ to 1K $\Omega$	
AFMS Output Capacitance	2.2 $\mu$ F $\pm$ 10%	
Levels (THD < 5 %)	Drive capability into 5 k $\Omega$ (0.3 - 3.5 kHz)	> 2.4 Vpp [TBC]
	Drive capability into 1.5 k $\Omega$ (0.3 - 3.5 kHz)	> 2.2 Vpp [TBC]
	Drive capability into 150 $\Omega$ (at 1kHz)	> 1.3 Vpp [TBC]

### 3.7 Microphone Signals

<i>Pin</i>	<i>Speaker signals</i>	<i>Dir</i>	<i>Function</i>
53	MICP	I	Microphone Positive Input
54	MICN	I	Microphone Negative Input

MICP and MICN are the microphone-input pins. These inputs shall be compatible with an electret microphone. The microphone contains a FET buffer with open drain output, which must be supplied with at least +2V relative to ground.

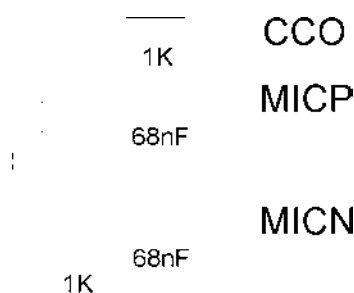

Figure 3.3 Microphone connection to module

CCO is the internal source voltage that will provide the necessary drive current for the microphone (This is not provided by the module).



<i>Parameter</i>	<i>Limit</i>
CCO	2.0 - 2.5 V

### 3.8 Speaker Signals

<i>Pin</i>	<i>Speaker signals</i>	<i>Dir</i>	<i>Function</i>
55	BEARP	O	Microphone Positive Output
56	BEARN	O	Microphone Negative Output

BEARP and BEARN are the speakers output pins. These outputs are in differential mode.

### 3.9 Digital Audio

<i>Pin</i>	<i>PCM signal</i>	<i>Dir</i>	<i>Function</i>
52	PCMCLK	O	PCM clock
51	PCMSYNC	O	PCM frame sync
47	PCMULD	I	PCM audio input to DSP
48	PCMDLD	O	PCM audio output to DSP
50	PCMI	I	PCM audio input to Codec
49	PCMO	O	PCM audio output to Codec

The digital PCM audio signals allow the connection of a digital audio source / receiver, bypassing the analogue audio CODEC processing functions performed within the module.

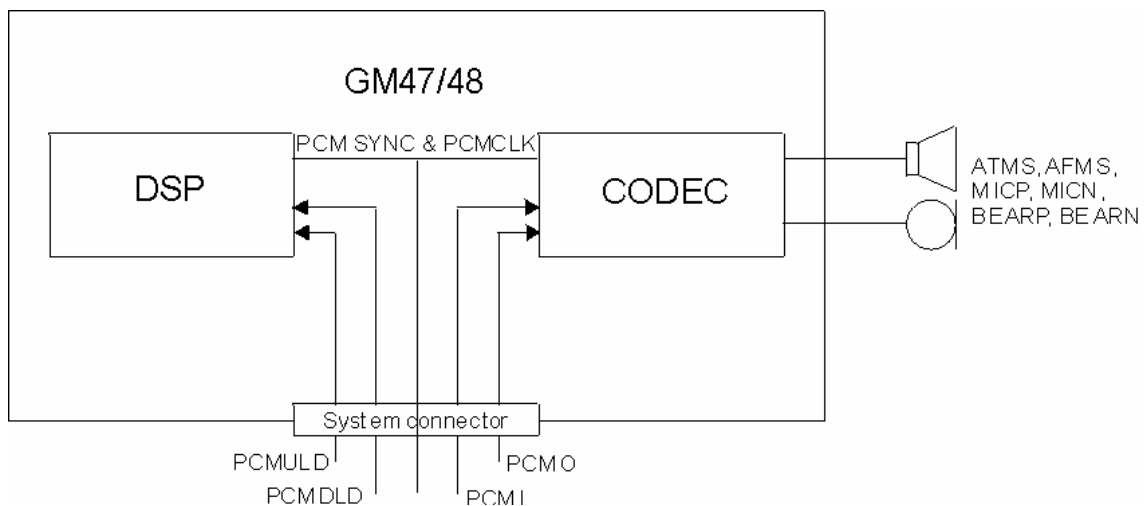

Figure 3.4 Pin connections to digital audio

In the case where no external audio processing is performed, then it is necessary to connect the following signals at the system connector:

PCMDLD and PCMI  
PCMULD and PCMO

*Electrical characteristics*

The Dig. 2.75 V CMOS Output / Input electrical characteristics shall apply, with DGND as the reference.

*PCM interface format*

The PCM format (for PCMULD and PCMDLD) shall follow a linear PCM data I/O format of an industry standard Texas Instrument DSP. It is the same format as the one used between the CODEC and the DSP. The DSP is the source of the bit clock PCMCLK and the frame synchronisation PCMSYNC. The data bits in PCMULD and PCMDLD shall be aligned so that the MSB in each word occurs on the same clock edge.

### 3.10 Serial Data

<i>Pin</i>	<i>Name</i>	<i>Dir</i>	<i>Description</i>	<i>RS232 CCITT N°</i>
41	TD	I	Serial data to module	103
42	RD	O	Serial data from module	104
39	RTS	I	Request To Send	105
	IO9	I/O	General purpose I/O 9	
40	CTS	O	Clear To Send	106
	KeyCOL4	O	Key column 4	
	O4	O	General purpose output 4	
37	DTR	I	Data Terminal Ready	108.2
	KeyROW1	I	Keyboard column 1	
	I/O1		General purpose I/O 1	
38	DCD	O	Data Carrier Detect	109
	KeyCOL1	O	Key column 1	
	O4	O	General purpose output 1	
36	RI	O	Ring Indicator	125
	KeyCOL2	O	Key column 2	
	O2	O	General output 2	
45	TD2	I	UART 2 Data Transmission	
46	RD2	O	UART 2 Data Reception	
43	TD3	O	UART 3 Data Transmission	
44	RD3	I	UART 3 Data Reception	

The serial channels are used as asynchronous communication links between an application system or accessory units connected to the Module. They consist of three UART's.

- UART 1 – This has full RS232 and is used for all on and off line communication.
- UART 2 – May be used for interfacing to a GPS unit, downloading software, receiving logging information, etc.
- UART 3 – May be used by embedded applications.

The Dig. 2.75 V CMOS Output / Input electrical characteristics shall apply, with DGND as the reference. Extra relevant data is specified for some of the signals.

The character format supported is, 1 start bit, 8 bit data, non-parity plus 1 stop bit, in total 10 bits per character.

*Note* : As stated in section 3.2.1 the module is unable to directly interface to a 3.3V micro processor.

Note 2 : As can be seen from the pin out table, several of the RS232 pins have multiple functionality, this is user selectable with the RS232 functionality set as default.

### 3.10.1 UART 1 (RS232) - RD, TD, RTS, CTS, DTR, DCD, DSR and RI

The UART1 signals form a 9 pin RS-232 (V.24) serial port.

The signal levels do not match the standard RS-232 (V.28) levels. The relationship between the levels is shown in the table below

<i>RS - 232 Level</i>	<i>RD, TD</i>	<i>RTS, CTS, DTR, DCD, RI</i>	<i>2.75 V CMOS Level</i>
< - 3 V	1	OFF	> 1.93
> + 3 V	0	ON	< 0.80 V

Conversion between the 2.75V CMOS levels and the RS232 levels can be achieved using a standard interface IC, such as the Maxim Integrated Products MAX3237.

### 3.10.2 Serial Data Signals - RD, TD

The default baud rate is 9.6 kbit/s, however higher bit rates up to 460 kbit/s are supported and are set by the AT+IPR command. The UART 1 starts at a rate of 9.6 kbit/s in standard AT mode or binary mode (First received data AT or binary will determine the operation mode). The GSM 07.10 multiplexing protocol is supported and is started on command, in this case bit rates up to 460 kbits/s are supported.

#### *Serial Data From Module (RD)*

RD is an output used to send data on the UART 1 to the application system. This is a Dig. 2.75 CMOS Output and general characteristics are applicable.

<i>Parameter</i>	<i>Limit</i>
Application load resistance	< 100 k $\Omega$
Application load capacitance	< 500 pF

#### *Serial Data To Module (TD)*

TD is input (to the module) used by the application system to send data on the UART 1 to the module. This is a Dig. 2.75 CMOS Input and general characteristics are applicable.

<i>Parameter</i>	<i>Limit</i>
Application driving impedance	< 100 $\Omega$
Input capacitance	1 nF
Input resistance (pull-down)	100 k $\Omega$ to 2.75 V

### 3.10.3 Control Signals - RTS, CTS, DTR, DCD, RI, DSR

The control signals are active low, and hence when a standard interface IC is used (such as MAX3237), then standard RS-232 levels are obtained.

These signals together with DGND, RD and TD form a 9-pin RS-232 data port (with the exception of the voltage levels).  
RTS and CTS shall be capable of transmitting at 1/10 of the data transmission speed for data rates, up to 460 kbit/s. (Byte oriented flow control mechanism).

*Switching times for RTS and CTS*

<i>Parameter</i>	<i>Limit</i>
Time from Low to High level	< 2 $\mu$ s
Time from High to Low level	< 2 $\mu$ s

*Request to Send (RTS)*

RTS is an input to the module. The signals on this circuit are used to condition the DCE (the module when used for data transmission purposes) for data transmission. Default level is OFF, by internal pull up.

The exact behaviour of RTS is defined by the AT+IFC command. Software or hardware flow control can be selected. Hardware flow control is the default.

This is a Dig. 2.75 CMOS Input and general characteristics are applicable.

It is the duty of the application to pull RTS low (logic levels) to request communications with the module. The module will respond by asserting CTS low and as such may be used as a notification as a module status ready for communication.

<i>Parameter</i>	<i>Limit</i>
Application driving impedance	< 100 $\Omega$
Input capacitance	< 2 nF
Input resistance (pull-down)	100 k $\Omega$ to DGND

*Clear To Send (CTS)*

CTS is an output from the module. The signals on this circuit are used to indicate that the DCE (the module when used for data transmission purposes) is ready to transmit data. Default level is high.

The exact behaviour of CTS is defined by the AT+IFC command. Software or hardware flow control can be selected.

This is a Dig. 2.75 CMOS Output and general characteristics are applicable.

Tip: if only software flow control is to be used it becomes necessary to assert RTS low or to connect RTS to CTS at the module.

<i>Parameter</i>	<i>Limit</i>
Application load capacitance	< 500 pF
Application load resistance	> 1 MΩ

*Data Terminal Ready (DTR)*

DTR is an input to the module. Signals from the DTE on this circuit indicate the DTE is ready to transmit and receive data. DTR also acts as a hardware 'hang-up' so that calls are terminated if DTR is OFF (high).

Default level is ON (low). The exact behaviour of DTR is defined by the AT&D command.

This is a Dig. 2.75 CMOS Input and general characteristics are applicable.

*Data Carrier Detect (DCD)*

DCD is an output from the module. An ON (low) signal shall indicate that a valid carrier (data signal) is being received by the DCE (module). The exact behaviour of DCD is defined by the AT&C command.

This is a Dig. 2.75 CMOS Output and general characteristics are applicable.

*Ring Indicator (RI)*

RI is an output from the module. An ON (low) signal indicates a ringing signal is being received by the DCE (module).

This is a Dig. 2.75 CMOS Output and general characteristics are applicable.

*DSR (Data Set Ready)*

The DSR signal must be switched on using the at&s command. If DSR is enabled it will indicate an active state (low) if the module is in command mode and inactive (high) if the module is in on line data mode.

### **3.10.4 UART 2 - TD2, RD2**

The UART 2 consists of a full duplex serial communication. This involves the transmission and reception lines.

The communication port shall work in one mode: Operation and Maintenance mode.

Operation and Maintenance mode shall work in addition with the SERVICE signal. On switching the module on, if SERVICE signal is active then two events can happen. If no data is sent to the module, then the logger is activated. Otherwise, the module shall be ready to be reprogrammed.

Timing and Electrical signal characteristics equal to UART 1 TD and RD, except for maximum baud rate that could be increased to 921 kbps.

*Transmitted Data 2 (TD2)*

TD2 is input (to the module) used by the application system to send data on the UART 2 to the module.

The electrical characteristics shall be the same as TD.

*Received Data 2 (RD2)*

RD2 is an output used to send data on the UART 2 to the application system.

The electrical characteristics shall be the same as RD.

### **3.10.5 UART 3 - TD3, RD3**

The UART 3 consists of a full duplex serial communication. This involves the transmission and reception lines.

Timing and electrical signals characteristics equal to UART 1 TD and RD.



*Transmitted Data 3 (TD3)*

TD3 is input (to the module) used by the application system to send data on the UART 3 to the module.

The electrical characteristics shall be the same as TD.

*Received Data 3 (RD3)*

RD is an output used to send data on the UART 3 to the application system.

The electrical characteristics shall be the same as RD.

**3.11 SIM Card related signals**

<i>Parameter</i>	<i>Mode</i>	<i>Signal</i>	<i>Min.</i>	<i>Typ.</i>	<i>Max.</i>	<i>Unit</i>
SIM supply Voltage	3 V	SIMVCC	2.7	3.0	3.3	V
	5 V		4.5	5.0	5.5	V
High Level Input Voltage ( $V_{IH}$ )	3 V	SIMDAT	2.1		3.0	V
	5 V		3.5		5.0	V
Low Level Input Voltage ( $V_{IL}$ )	3 V	SIMDAT	0		0.9	V
	5 V		0		1.5	V
High Level Output Voltage ( $V_{OH}$ )	3 V	SIMDAT	2.7		3.0	V
	5 V		4.7		5.0	V
Low Level Output Voltage ( $V_{OL}$ )	3 V	SIMDAT	0		0.2	V
	5 V		0		0.2	V
High Level Output Voltage ( $V_{OH}$ )	3 V	SIMCLK	2.4		3.0	V
	5 V	SIMRST	4.4		5.0	V
Low Level Output Voltage ( $V_{OL}$ )	3 V	SIMCLK	0		0.35	V
	5 V	SIMRST	0		0.3	V

### 3.11.1 SIM Detection – SIM Presence

SIMPRESNCE is an input intended to be used to determine whether a SIM card has been inserted or removed in the external SIM card holder. It shall be normally wired to the "Card Inserted Switch" of the external SIM card holder.

When left open an internal pull up resistor maintains the signal high and means 'SIM card missing' to the module. When pulled low the module assumes a SIM card is inserted.

SIMPRESNCE is a digital CMOS 2.75 input with the following characteristics.

<i>Parameter</i>	<i>Min.</i>	<i>Typ.</i>	<i>Max.</i>	<i>Units</i>
Pull-up resistance (at 2.75 V)	100			kΩ
Low Level Input Voltage (SIM inserted)			0.8	V
High Level Input Voltage (SIM missing)	1.93		5	V

Note : The module has been Type Approved with SIM presence implemented, to avoid extra testing when type approving the application this should be designed in.

### 3.12 Service/Programming

<i>Pin</i>	<i>Signal</i>	<i>Description</i>
58	SERVICE	Flash programming voltage

This input shall be used as a programming voltage for the Flash Memory to initiate and it is also used as a signal to indicate to the module that it should start outputting logging information.

<i>Mode</i>	<i>SERVICE Voltage (V)</i>			<i>Drive Capacity</i>
	<i>Min.</i>	<i>Typ.</i>	<i>Max.</i>	
Normal Operation			0.8	-
Service/enable programming	1.9	2.75	3.6	> 1 mA
Absolute maximum voltage			13.5	-

### 3.13 Buzzer

<i>Pin</i>	<i>Signal</i>	<i>Description</i>
31	Buzzer	Buzzer output from the module

This is an output signal which allows the application to use pre-programmed melodies or sounds. Typical use would involve a transistor buffer with a piezoelectric sounder.

The Dig. 2.75 V CMOS Output electrical characteristics shall apply, with DGND as the reference.

### 3.14 LED

<i>Pin</i>	<i>Signal</i>	<i>Description</i>
33	LED	LED Output from module
	I/O6	General purpose I/O 6

This is an output signal which allows the use of an external LED. The LED shall indicate different states within the module.

This signal is a Dig. 2.75 V CMOS output so general characteristics are applicable. In order to connect a LED in the external application the following scheme shall be followed.

The operation of the LED is hardcoded and is not controlled by the host application.

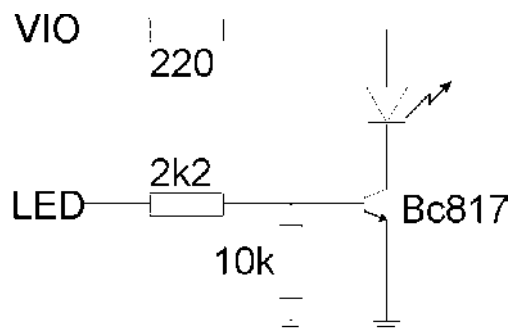

Figure 3.5 Electrical connection for LED

### 3.15 TX\_ON - Burst Transmission

<i>Pin</i>	<i>Signal</i>	<i>Dir</i>	<i>Description</i>
35	TX_ON	O	GSM module on transmission

The TX\_ON is a digital signal output. This shall indicate that the module is going to transmit the burst. Burst transmission is the time when a GSM transceiver unit is transmitting in its timeslot assigned by the network.

Dig 2.75 CMOS Output so general electrical characteristics are applicable.

### 3.16 Real Time Clock

The Real Time Clock provides the module with a time-of-day calendar with alarm and one hundred-year calendar to the main microprocessor.

The real time clock operates with a separate power supply. Therefore, two modes of operation shall be distinguished:

- RTC Normal operation: This is when the MS is powered/Vcc present and it does not take into account if the MS is in OFF or ON.
- RTC Backup operation: This operation is performed when the MS is not powered, VCC = 0V. In this case the RTC operation is maintained by the backup power supply.

The backup power supply is a passive power supply, capacitor, golden- capacitor, battery etc., which shall be connected outside the MS to VRTC pin. During the RTC normal operation, the passive power supply is being charged; this is like charging a capacitor.

In backup operation, the backup source provides with enough voltage for RTC operations. The following table shows both voltage operations characteristics.

<i>Parameter</i>	<i>Min.</i>	<i>Typ.</i>	<i>Max.</i>	<i>Units</i>
Supply Voltage RTC (Normal Operation – Charging the capacitance)	1.6	1.8	2.0	V
Supply Voltage RTC (Backup Operation – Capacitance provides with voltage)	1.0	1.8	2.0	V
Current drawn		5.0	10.0	μA

In Back-up operation if the voltage drop below 1 Volt, the RTC shall stop working. The following diagram shows the RTC connection:

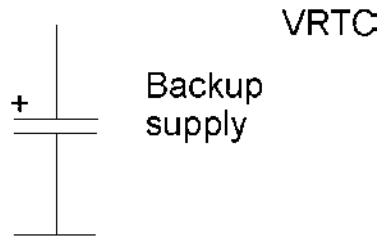

Figure 3.6 RTC connection

### 3.17 Extended IO capabilities

In order to increase the flexibility and variety of GR47 peripherals, the RS232 hardware flow control shares its physical interface with the keypad scanning interface and extended general purpose IO capability. Due to the nature of this sharing, it is not feasible to operate all these features concurrently (although, with care, dynamic switching from one feature to another and back is possible).

When a particular feature is required of an IO, the software automatically sets the states of the relevant IO blocks disabling one set and enabling others. This is most noticeable with the RS232 hardware flow control when switching on the keypad functionality.

If full hardware flow control and handshaking is required there will be no available keypad column drivers and the keypad interfacing will be disabled. If intermediate hardware flow control is selected (RTS and CTS only), the unused flow control pins (DTR, DCD, RI, DSR) are made available to the keypad interface providing three discrete matrix column drivers.

If RS232 hardware flow control is switched off altogether, the remaining keypad column driver is enabled allowing the full keypad matrix of 5 columns by 4 rows.

#### 3.17.1 LED/IO6

The LED function pin can be used as a general purpose digital IO when the flashing LED function is not required. However, this pin does not have an on-board pull-up resistor. It is required that an external pull-up or pull-down resistor be provided by the host circuitry when either not used or when used as a digital input.

### 3.17.2 I#/O#

When not being used for an alternative function the pins labelled I# and O# may be used for general purpose inputs or outputs respectively. The inputs have an on-board 100k pull-up resistor and the outputs are driven rail-to-rail at 2.75V levels.

### 3.17.3 UART3/IO#

The UART3 pins have been given alternative functions as general purpose I/O, both pins may be used for either input or output. However, the TX pin has a 100kΩ pull-down resistor to ground and the RX pin has a 100kΩ pull-up resistor to 2.75V. This must be taken into consideration when designing the host circuit.

### 3.17.4 IO#/ADC#

To increase analog input capabilities, the GR47 optimises the IO by multiplexing or sharing different features on single pins. There are two digital IO pins which now have an additional ADC input. When configured as digital IO, the software will not read the voltages at the two new ADC inputs. When configured as ADC inputs the software will configure the digital IO pins as input or high impedance tri-state. In this state any applied voltage between 0V and 2.75V can be read as an 8 bit value.

Because the additional ADC inputs (ADC4 and ADC5) are common with digital IO, the input circuit of the ADC is not the same as for the original circuits ADC1-3. It is important to understand the input structure of the pin so that the correct analog voltage is read by the application. The input structure is provided in figure 3.7. It consists of a 100kΩ pull-up to 2.75V followed by a series 1kΩ and 10nF capacitor to ground which make a low pass filter with a 3dB roll-off at about 16kHz. The input impedance of the analog IC is 1MΩ minimum.

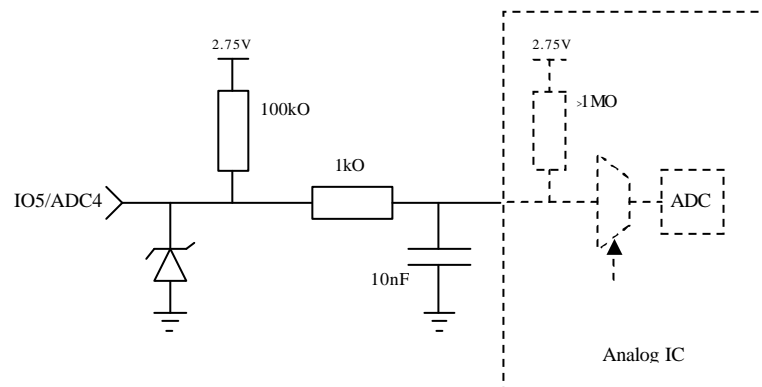

Figure 3.7 Input circuit for combined digital IO and ADC pins

### **3.18 Keyboard interface**

To increase IO capabilities, the GR47 optimises the IO by multiplexing or sharing different features on single pins. The IO has been extended to allow simple interfacing of a matrix keypad.

#### **3.18.1 IO#/KEYROW#**

When configured for keypad operation the software will configure the digital IO pins as input or high impedance tri-state. In this state, the keypad matrix row can be read from the KEYROW# inputs. These pins have a 100kΩ pull-up to 2.75V and the rows are considered activated when the voltage is pulled low by the external keypad switches.

#### **3.18.2 KEYCOL#**

The keypad matrix column drivers share functionality with the RS232 hardware flow control signals. When configured for keypad operation the software will configure the hardware flow control to either intermediate or off.

With intermediate flow control the number of keypad column outputs is limited to three, with flow control switched off, the number of keypad column outputs is increased to four. In addition to the keypad column outputs it is possible to use a direct ground connection as an additional column driver, which is interpreted as column zero.

Thus it is possible to create a variety of keypad matrix sizes from single column to five columns wide.

Finally, a standard keypad matrix directly connects the rows to the columns whenever a key is depressed. In order to avoid short circuits if multiple keys are pressed simultaneously, the column drivers must be open-collector. This must be achieved with external transistors as the logic drive from the GR47 is rail-to-rail. Suitable transistors for this interface are of the type with built in bias resistors between base and emitter.

The method of connection is shown in 3.8 below.

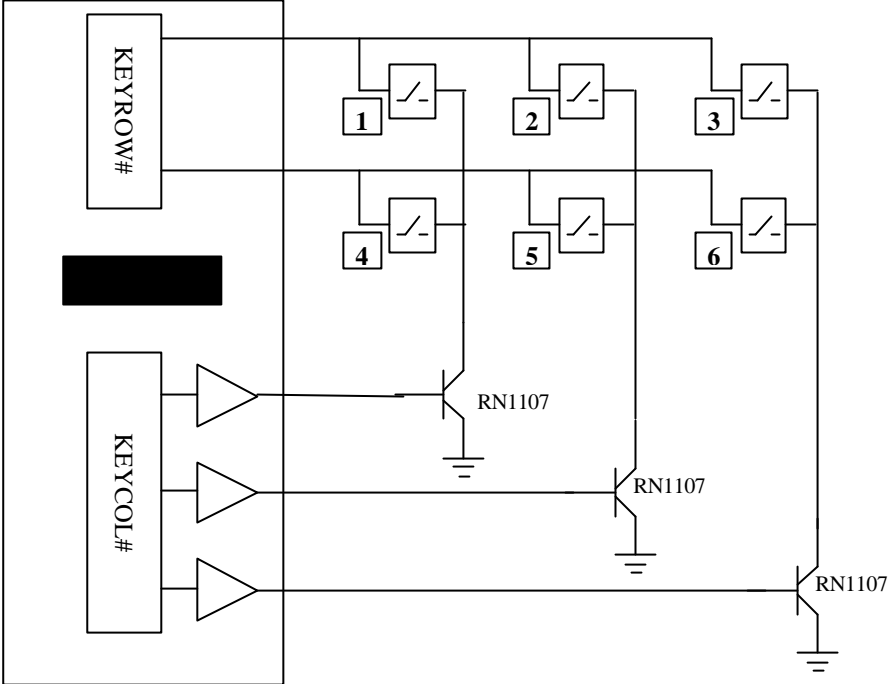

Figure 3.8 Keyboard matrix connections



---

## 4 Antenna Connector

The Antenna Connector is a hub for transmission of the Radio Frequency (RF) signals from the module to the external customer-supplied antenna. It is a MMCX connector that is mounted on the surface of the module. Most dealers should be able to supply this type of connector.

This table provides the electrical characteristics at the antenna interface.

<i>Parameter</i>	<i>Limit</i>	<i>Description</i>
Nominal impedance	50 $\Omega$ (SWR < 2:1)	
Output Power	2 Watt peak (Class 4)	Extended GSM 900
	1 Watt peak (Class 1)	GSM 1800
Static Sensitivity	Better than - 102 dBm	Extended GSM 900
	Better than - 102 dBm	GSM 1800

## 5 AT Command Summary

The AT standard is a line-oriented command language. "AT" is an abbreviation of ATtention and it is always used to start sending a command line from a TE to the TA. TE stands for Terminal Equipment which is a computer of any size and TA stands for Terminal Adapter which is the modem part of the module.

The command line consists of a string of alphanumeric characters. It is sent to the modem to instruct it to perform the commands specified by the characters.

<i>Functionality</i>	<i>AT commands</i>
<i>CONTROL AND IDENTIFICATION</i>	
Subscriber Information	AT+CNUM, AT+CIMI, AT*ESNU
Product & Release info	AT+CGMR, AT+CGSN, AT*ESIR
Generic information & Settings	AT, AT*, AT+CLAC, AT+GCAP, ATI, AT+CSCS, AT&F, AT&W, ATZ, AT+WS46, AT*E2SSN
<i>CALL CONTROL</i>	
General call control	ATA, ATD, ATL, ATH, ATP, ATT, AT+CHUP, AT+CMOD, AT+CVHU, AT+CR, AT+CRC,
DTMF	AT+VTS
Data commands	ATO, AT+CRLP
<i>AUDIO CONTROL</i>	
Audio profile modification	AT*E2EAMS
Audio profile manipulation	AT*EALR, AT*EAMS, AT*EARS, AT*ELAM, AT*EMIR, AT*EMIC, AT*EXVC, AT*E2APR
<i>NETWORK SERVICES</i>	
Alternate Line Service (ALS)	AT*EALS, AT*ELIN, AT*ESLN
Customer Service Profile	AT*ECSP
Call forwarding	AT+CCFC, AT*EDIF
Calling/called number identification	AT+CLIP, AT+CLIR, AT*EIPS
Preferred networks	AT*EPNR, AT*EPNW
Advice of Charge	AT+CACM, AT+CAMM, AT+CAOC, AT+CPUC
Calling cards	AT*ESCN
Call hold, waiting & multiparty	AT+CCWA, AT+CHLD
Operator selection	AT+COPS

Network registration	AT+CREG
USSD	AT+CUUSD, AT+CSSN
Security & Locks	AT+CLCK, AT+CPWD, AT+CPIN, AT*EPEE
<i>SETTINGS</i>	
Restting	AT*EMAR
Ring signal settings	AT*ERIL, AT*ERIN, AT*ERIP, AT*ESIL, AT*ESMA, AT*ESMM, AT*ESOM
<i>ME STATUS INFORMATION</i>	
	AT*ECAM, AT+CSQ, AT+CIND, AT+CPAS, AT+CMER
<i>ERROR CONTROL</i>	
	AT+CMEE, AT+CEER
<i>SMS &amp; CB</i>	
Settings	AT*ESTL, AT+CPMS, AT+CRES, AT+CSAS, AT+CSCA, AT+CSMS, AT+CNMI, AT+CSDH, AT+CSMP, AT+CGSMS
SMS-Command	AT+CMGC
Read / write SMS	AT+CMGD, AT+CMGW, AT+CMGL, AT+CMGR
Send SMS	AT+CMGS, AT+CMSS
<i>PHONEBOOK</i>	
Read / write / find	AT+CPBS, AT+CPBR, AT+CPBW, AT+CPBF
Groups	AT*EGIR, AT*ESAG, AT*ESCG, AT*ESDG, AT*ESDI, AT*ESGR
Personal Rings	AT*EPRR, AT*EPRW
Settings	AT*EPBM, AT*E2PBCS
<i>CLOCK</i>	
Alarm	AT+CALA, AT+CALD, AT+CAPD
Time & Date	AT+CCLK, AT+CTZU, AT*EDST
<i>INTERFACE COMMANDS</i>	
Flow control	AT&C, AT&D, AT+ICF, AT+IFC, AT+IPR, AT&S
S registers	ATS0, ATS10, ATS2, ATS3, ATS4, ATS5, ATS6, ATS7, ATS8
Response control	AT+ILRR, ATE, ATV, ATQ, AT+CSCS, ATX
<i>07.10 MULTIPLEXING</i>	
	AT+CMUX

---

HSCSD	AT+CHSR, AT+CHSU
<i>GPRS</i>	
PDP Context Activation	AT+CGACT
GPRS Attachment	AT+CGATT
Enter Data State	AT+CGDATA
Define PDP Context	AT+CGDCONT
GPRS Event Reporting	AT+CGEREP
Show PDP Address	AT+CGPADDR
Quality of Service Profile (MINIMUM ACCEPTABLE)	AT+CGQMIN
Quality of Service Profile (REQUESTED)	AT+CGQREQ
GPRS Network registration Status	AT+CGREG
Extension of ATD for GPRS	ATD*
<i>NETWORK INFORMATION</i>	
Cell information	AT*E2CD
Engineering Mode	AT*E2EMM
<i>SIM APPLICATION TOOLKIT</i>	
Set Up Call	AT*E2STKC
Display Text	AT*E2STKD
Get Inkey	AT*E2STKG
Get Input	AT*E2STKI
Select Item	AT*E2STKL
Set Up Menu	AT*E2STKM
Envelope (Menu Selection)	AT*E2STKN
Application Toolkit Settings	AT*E2STKS

---

## 6 Embedded applications

The module has the capability to store and run customer written code in the form of a script during the processors idle time, through the use of an on board interpreter.

### 6.1 Features

Main features of embedded applications are as follows.

- C based scripting language (SEM specific)
- Over the air upgradeable (scripts, NOT signalling software)
- Library of intrinsic functions
- Multiple on module script support

### 6.2 Implementation

The module has upto 44k of space available for storage of two scripts in the scripting language and 25k of operating RAM. Structures included in this language are

- If - then - else statements
- While loops
- For loops

All hardware interfaces that are normally available to the module through the AT commands are available to the embedded application. Further drivers have been written such as M bus and I<sup>2</sup>C for use by the EA through the use of the IO pins.

#### 6.2.1 Limitations

Since the module is processing the script using its own memory limitations are placed onto the scripts that are run.

- A direct comparison cannot be made to a fully compiled C program in terms of size but a gauge of script size is that if each line were 128 characters long in the script then the script could be 350 lines long.
- Processing power is something that needs to be considered as the script is run as a low priority process within the software. An option that can be used to stop this controller mode, this stops GSM operation and provides all processing power for the script to be run.
- Code cannot be ported directly from an existing application and loaded directly onto the module. It must be re written in the SEM script language so that the module interpreter can function correctly.

## **6.2.2 M2mpower IDE (Integrated Developers Environment)**

The IDE is a windows based package which allows the user to write simulate, de-bug and download their application into a module with the EA software. The standard version is designed to run on Windows XP and 2000, other versions are available for 98 if required.

A guide is available for implementing applications using the developers kit and the EA functionality.

This is a required package to be able to implement an EA.

For further information please contact SEM customer support.

## 7 TCP/IP stack

An on board IP/TCP/UDP stack has been integrated into the software negating the need for the customer to implement one in their own code base.

This is going to initially only be accessible through the embedded applications (see previous section) using intrinsic functions.

### 7.1 Implementation

There are a number of commands allowing various functions, these are as follows.

- Open/closing IP connection – Negotiates/closes a dynamic IP address with the web server.
- Send/Receive TCP packets – Performs all TCP operations to send and receive packets.
- Send/Receive UDP packets – Performs all UDP operations to send and receive packets.
- Resolve URL to an IP address - Similar to nslookup command in DOS

When the unit is set up and controlled using the embedded applications either the EA or an external application can generate data to be sent and can pass it to the module for transmission.

This effectively provides a transparent communication link to an internet server from the application over GPRS.

## 8 Technical Data

### *Mechanical specifications*

Maximum length:	50 mm
Maximum width:	33 mm
Maximum thickness:	6.82 mm (without system connector pins length)
Weight:	18,5 g

### Power supply voltage, normal operation

Voltage:	3.6V Nominal
Tolerance	-0.2 +0.4V
Ripple:	<100mV @ 200KHz, <20mV @>200KHz

Voltage must always stay within a normal operating range, ripple included.

Power consumption:	Speech mode < 250 mA (< 2 A peak) Idle mode: <5 mA Powered off: < 100 $\mu$ A
--------------------	---

RTC accuracy:	Max < 37ppm Typical < 20ppm
---------------	--------------------------------

### *Radio specifications*

Frequency range:	GR 47: GSM 900 & EGSM 900 MHz and 1800 MHz (Dual Band) GR 48: GSM 850 MHz and 1900 MHz (Dual Band)
Maximum RF output power:	2 W / 1 W
Antenna impedance:	50 $\Omega$

### *SIM card*

SIM card interface (external only)	3 V or 5 V
------------------------------------	------------

### *Environmental specifications*

Operating temperature range:	-25 $^{\circ}$ C to +55 $^{\circ}$ C
Storage temperature range:	-40 $^{\circ}$ C to +85 $^{\circ}$ C
Maximum relative humidity:	95% at +40 $^{\circ}$ C
Stationary vibration, sinusoidal:	Displacement: 7.5 mm Acceleration amplitude: 20 m/s <sup>2</sup> 40 m/s <sup>2</sup> Frequency range: 2-8 Hz 8-200 Hz 200-500 Hz
Stationary vibration, random	Acceleration spectral density (m <sup>2</sup> /s <sup>2</sup> ): 0.96 2.88 0.96 Frequency range: 5-10 10-200 200-500 60 min per/axis



Non-stationary vibration, including shock Shock response spectrum I, peak acceleration: - 3 shocks in each axis and direction: 300 m/s<sup>2</sup>, 11 ms

Shock response spectrum II, peak acceleration: - 3 shocks in each axis and direction: 1000 m/s<sup>2</sup>, 6 ms

Bump:	Acceleration 250 m/s <sup>2</sup>
Free fall transportation:	1.2 m
Rolling pitching transportation:	Angle: ±35 degrees, period: 8s
Static load:	10 kPa
Low air pressure/high air pressure:	70 kPa / 106 kPa

#### Storage

SMS Storage capacity	40 in ME In addition the unit can handle as many SMS as the SIM can store (SIM dependent).
Phone book capacity	100

#### DAC

Parameter	Value	Units
Resolution	8	bit
Output voltage swing for Code=00 <sub>HEX</sub>	0.138 ± 0.1	V
Output voltage swing for Code=FF <sub>HEX</sub>	2.61 ± 0.2	V
Nominal Step Size	9.668 ± 0.1	mV
Linear Code Range	8-247 (8 <sub>H</sub> -F7 <sub>H</sub> )	LSB
Absolute Error during Linear Range	±100	mV
Conversion Speed	<100	µs

#### ADC

Parameter	Value	Units
Resolution	8	bit
Input voltage for Code=00 <sub>H</sub>	0.01 ± 0.01	V
Input voltage for Code=FF <sub>H</sub>	2.75 ± 0.1	V
Nominal Step Size	10.742	mV
Accuracy	±3	LSB
Input Impedance	>1	MΩ
Conversion Time to within 0.5bit	<100	µs

## 9 Contact details

To contact customer support please use the details below.

Customer Support  
Maplewood Building  
Chineham Business Park  
Basingstoke  
RG24 8YB

E mail :

[modules.support@sonyericsson.com](mailto:modules.support@sonyericsson.com)

Or

[modules.info@sonyericsson.com](mailto:modules.info@sonyericsson.com)